



MAC100



BM11



Macina pane per pane tostato. Setaccio reversibile con doppia granulometria. Micro di sicurezza

Bread mill for toasted bread. Reversible sieve with double grain size. Safety microswitch

Moulin à pain pour pain grillé. Tamis réversible à double granulométrie. Equipé de micro-interrupteur de sécurité

Molino de pan para el pan tostado. Tamiz reversible con doble tamaño de grano. Microinterruptor de seguridad

Мельница для поджаренного хлеба. Реверсивное сито с двойной granulometрией. Наличие концевого выключателя безопасности

Brotmühle für geröstetes Brot. Reversibles Sieb mit Doppelkörnergröße. Mit Sicherheitsmikroschalter ausgestattet

Specifiche tecniche - Technical specifications - Fiche technique



X = Standard O = Optional

MAC 100

BM11

Corpo in acciaio inox e alluminio - S/steel and aluminum frame - Structure en inox et aluminium	X	
Micro sicurezza - Safety micro - Micro-interrupteur de sécurité	X	
Produzione oraria kg max(*) - Max hourly production(*) - Production max. horaire kg (*)	80	140
Setaccio 3-4 mm - 3-4 mm sifter - Tamis 3-4 mm	X	
Setaccio 5-6 mm - 5-6 mm sifter - Tamis 5-6 mm	O	
Setaccio 8-10 mm per mollica - 8-10 mm sifter for fresh bread - Tamis 8-10 mm pour mie		O
Kit per mollica di pane - Fresh bread kit - Kit pour mie		O
Kit gambe h.410 mm - Leg kit h.410 mm - Kit jambes h.410 mm		O
Voltaggio / kw - Voltage / kw - Voltage / kw	400V-3ph-50/60Hz-0,75Kw	400V-3ph-50/60Hz-1,5Kw
Peso netto / lordo kg - Net / gross weight kg - Poids net / brut kg	22 / 31	31 / 40
Dimensioni imballo cm - Packing dimensions cm - Dimensions emballage cm	57 x 99 x h81	

(*) Pane tostato - **Toasted bread** - Pain toasté

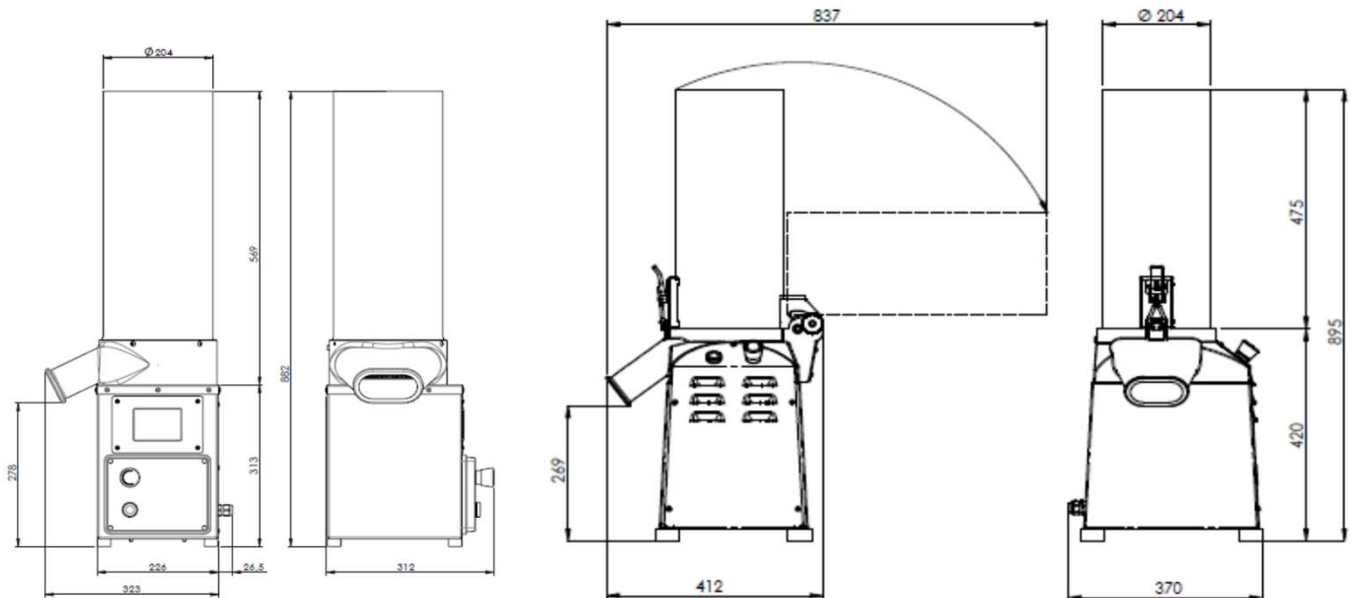

MAC100

BM11