

0.55 Kw

50/60Hz  
230V

Sfogliatrice verticale compatta da tavolo adatta alla laminazione della pasta in genere, delle piadine, della pizza tradizionale e al taglio. Velocità regolabile con inverter. Adatta a ristoranti, comunità e pizzerie

**Compact table-top vertical sheeter suitable for laminating traditional and sliced pizza and dough in general. Inverter-adjusted speed. Suitable for restaurants, community centres and pizzerias**

Laminadora vertical compacta para banco apta para la laminación de la masa en general, para la pizza tradicional y para corte. Velocidad ajustable con inverter. Apta para restaurantes, comunidades y pizzerías

Laminoir vertical compact à table, idéale pour le laminage de la pâte en général, pour la pizza traditionnelle et en tranches. Cadence réglable par onduleur. Idéale pour les restaurants, les communautés et les pizzerias

Компактная вертикальная настольная тестораскаточная машина, предназначена для раскатки различных видов теста, а также теста для традиционной и порционной пиццы. Скорость регулируется посредством инвертера. Предназначена для ресторанов, общественных заведений и пиццерий

	SHV
Larghezza cilindri - Roller width	500 mm



# Specifiche tecniche / Technical specifications

× Standard ○ Optional

	RV50	SHV	S5BM	SH50B-SH60B	SH500-SH600	SH6002	R62   R62-T	R65   R65-T	R65S   R65S-T	R65A   R65A-T	R65AX   R65AX-T	EUROSTAR
Inversione ciclo con joystick <b>Joystick cycle reversal</b>			×	×	×							
Inversione ciclo con barra <b>Bar cycle reversal</b>						×						
Inversione ciclo con impulso elettrico <b>Electric cycle reversal</b>							×	×	×			
Inversione ciclo a pedale <b>Pedal cycle reversal</b>					○		○	○				
Tavoli removibili <b>Removable tables</b>						×	× <sup>(1)</sup>	× <sup>(1)</sup>	× <sup>(1)</sup>	× <sup>(1)</sup>	× <sup>(1)</sup>	× <sup>(1)</sup>
Sfarinatore automatico <b>Automatic flour duster</b>								○	○	○	×	×
Avvolgitore automatico <b>Automatic reeler</b>								○ <sup>(2)</sup>	○	○	×	×
Regolazione velocità con Inverter <b>Inverter speed regulation</b>		×		○	○	○	○ <sup>(3)</sup>	○ <sup>(3)</sup>	×	×	×	×
Unità di taglio <b>Cutting unit</b>						○	○ <sup>(3)</sup>	○ <sup>(3)</sup>	○ <sup>(3)</sup>	○ <sup>(3)</sup>	○ <sup>(3)</sup>	○
Carrello <b>Trolley</b>				○								
Ripiano intermedio con bacinelle <b>Shelf with basins</b>							○ <sup>(1)</sup>	○ <sup>(1)</sup>	○ <sup>(1)</sup>	○ <sup>(1)</sup>		
Kit 2 tavoli intermedi con bacinelle <b>Kit 2 intermediate shelves with basins</b>											○	

(1) Con alcune limitazioni / **With some limitations** - (2) Solo modelli con inverter / **Inverter models only** - (3) Standard su versioni T / **Standard on T version**



**RV50**

**SHV**

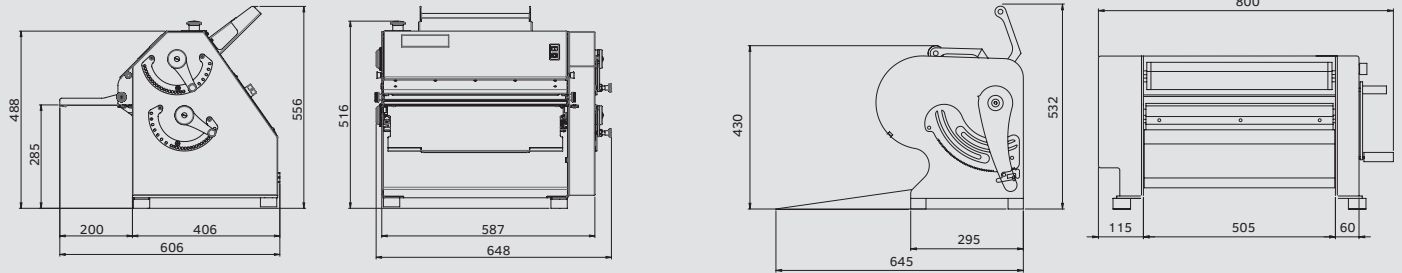

**KG** 85 Kg

**KG** 70 Kg

**S5BM**

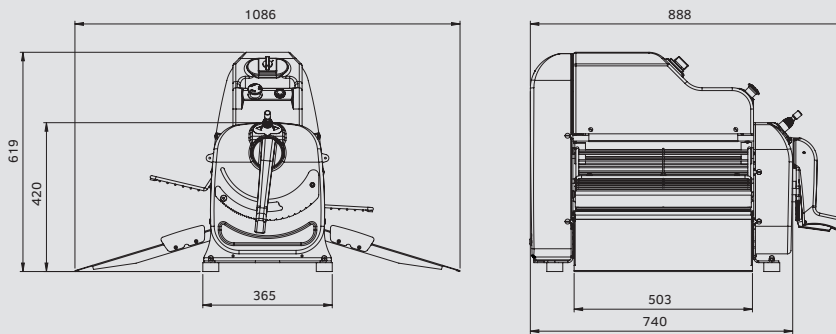

**KG** 81 Kg

**SH50B / SH60B**

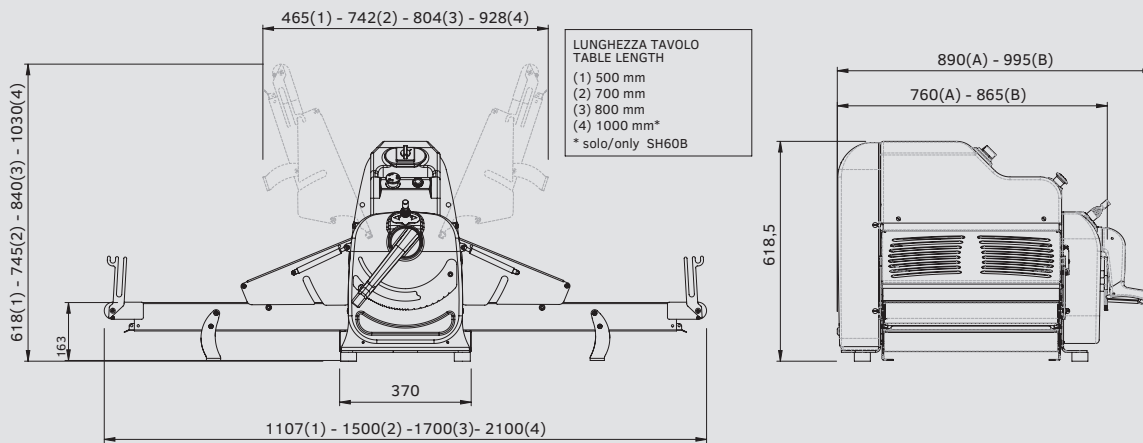

**KG** 91 ÷ 120 Kg