

0.55 Kw

50/60Hz
380V



Modello manuale da banco per un utilizzo generico. Per la sua compattezza il modello G42 è adatto al retrobanco del negozio, al piccolo laboratorio e al ristorante

Counter-top manual model for general use. Thanks to its compact size, the G42 model is suitable for behind-the-counter use in shops, small laboratories and restaurants

Modelo manual para banco para un uso genérico. Por su estructura compacta el modelo G42 es apto para el mostrador de las tiendas, los talleres pequeños y los restaurantes

Modèle manuel à banc pour une exploitation standard. Grâce à ses dimensions compactes, le modèle G42 est idéal pour l'arrière comptoir des magasins, les petits laboratoires et les restaurants

Настольная модель оборудования для общего использования с ручным режимом нарезки. Благодаря компактным размерам модель G42 может использоваться в магазинах, на маленьких хлебокондитерских предприятиях и в ресторанах

Manuelles Tischmodell für eine allgemeine Verwendung. Aufgrund seiner Kompaktheit ist das Modell G42 für den rückwärtigen Tisch von Geschäften, für kleine Gewerbebetriebe und Restaurants geeignet

	G42
Modello - Model	Manuale da tavolo / Manual bench type
Carico - Loading	Frontale / Front
Lunghezza nominale taglio - Nominal width cut	420 mm
Dimensione max. pane mm - Loaf max. dimensions mm	400 x 300 x 180h
Passo lame - Blade pitches	Scelta da 9 a 20 mm / Available from 9 to 20 mm

✗ Standard ○ Optional

Specifiche tecniche / Technical specifications



	G42	C42-C52	CP42-CP52	C42S-C52S	CP42S-CP52S	ST42	SA35-SA50	MI52	MR52	MAC100	BM11
Struttura in acciaio verniciata Steel powder painted body	✗	✗	✗	✗	✗	✗	✗	✗	✗		
Modello da tavolo Bench model	✗	✗	✗								
Modello con ruote Models on wheels					✗	✗	✗	✗	✗		
Manuale Manual	✗	✗	✗	✗							
Automatica Automatic			✗		✗	✗	✗	✗	✗		
Automatica a ciclo singolo e continuo Automatic single and continuous mode			✗		✗						
Automatica a ciclo continuo Automatic continuous cut								✗	✗		
Automatica con 4 modalità di taglio Automatic with 4 cutting modes							✗				
Carico frontale Front loading	✗	✗	✗			✗	✗				
Carico laterale/posteriore Lateral/rear loading				✗	✗			✗	✗		
Passo fetta variabile Adjustable pitch							✗				
Telaio coltelli intercambiabile (brevetto) Interchangeable blade cartridge (patent)									✗		
Regolazione elettrica tappeto superiore Electrically adjustable upper conveyor								✗	✗		
Regolazione velocità con inverter Speed regulation with inverter								✗	✗		
Velocità tappeto e telai indipendenti Independent speed of conveyor and cutting frames								✗	✗		
Insufflatore Bag blower				○	○						
Base con ruote Base with wheels	○	○	○								
Oliatore Oiling system	○	○	○	○	○	○	○	○	○		
Struttura in alluminio e inox Aluminum & s/steel structure										✗	✗
Kit mollica Fresh bread knife kit											○
Piedini inox S/steel legs											○



Dimensioni / Dimensions

Peso netto / Net weight

G42

C42/C52

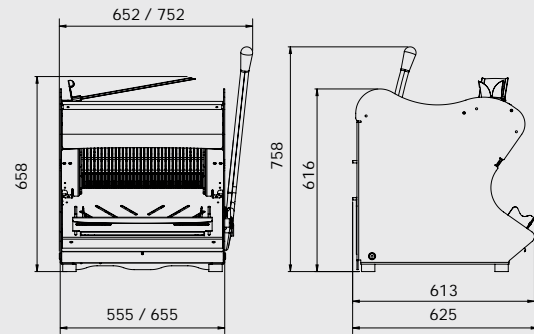
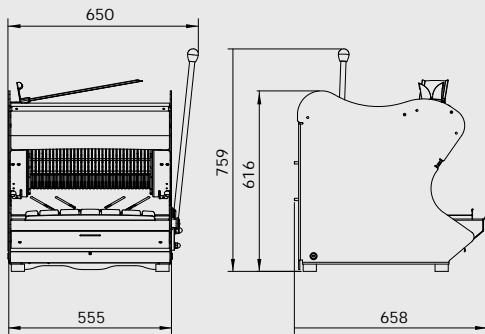

98 Kg.

101 / 107 Kg.

CP42/CP52

BASE

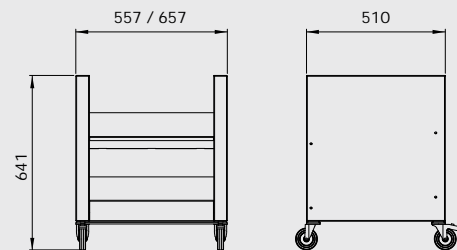
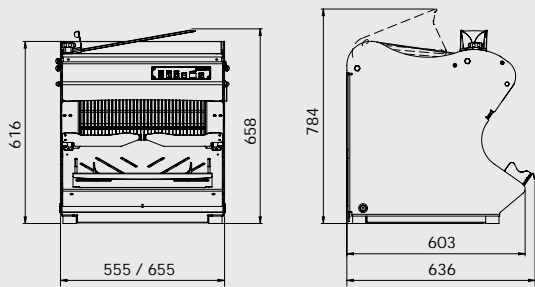

101 / 107 Kg.

28 / 30 Kg.

C42S/C52S

CP42S/CP52S

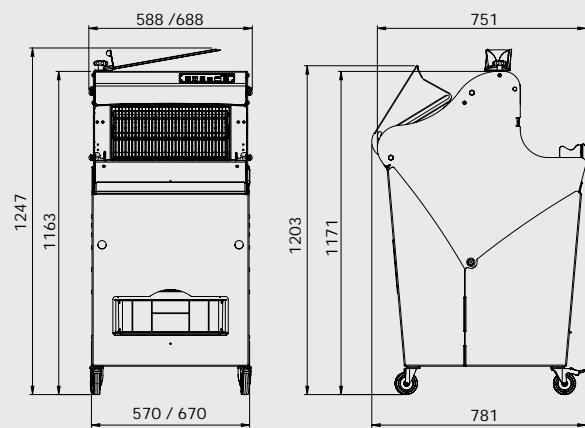
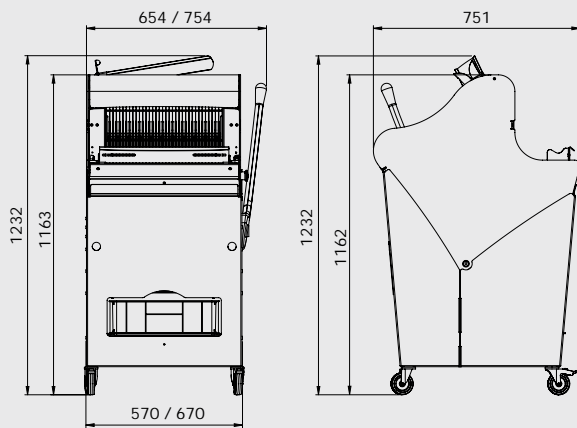

135 - 142 Kg.

135 - 142 Kg.